



AIR CONDITIONING



REFRIGERATION



HEATING



# hi-flow 1L & 2L

## CONDENSATE REMOVAL PUMP

Proven reliability and performance. The evolution of this world class tank pump means it's more engineer focused and even easier to install and maintain... when time is precious look no further.



288L/h max. flow



5m max. rec. head (flow rate 10L/h)

### KEY FEATURES

- Easy access tank
- Twist & click non return outlet barb
- Built-in spirit level

### SUITABILITY

- Up to 384kW / 1.3m Btu/h
- Ducted units; Floor standing & Chassis units; Cassette unit

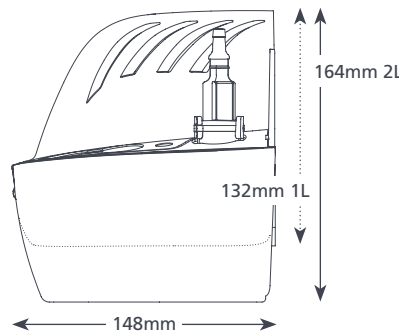
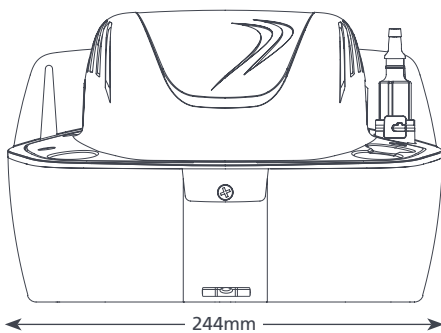

### HI-FLOW 1L & 2L SPECIFICATIONS

|                    |                        |
|--------------------|------------------------|
| Max. flow          | 288L/h @ 0 head        |
| Max. rec. head     | 5m                     |
| Tank capacity      | 1L & 2L                |
| Sound level@1m     | 55dB(A)                |
| Power supply       | 230V AC 50-60Hz 0.6A*  |
| Rated              | Continuously           |
| Class              | I appliance            |
| Max. output        | 384kW / 1.3m Btu/h     |
| Max. water temp    | 40°C / 104°F           |
| Inlet/outlet       | x3 27mm in, 6-10mm out |
| IP Protection      | IPX0                   |
| Safety switch      | 3.0A Normally closed   |
| Thermal protection | ✓                      |
| Fully potted       | n/a                    |
| Self priming       | n/a                    |

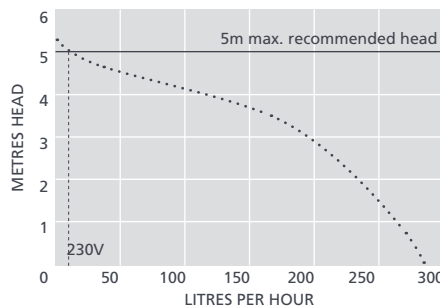

### SUGGESTED XTRA ACCESSORIES

| Description                   | Part No. |
|-------------------------------|----------|
| Tank pump connector 16mm-21mm | FP2011   |
| Tube To Soil Stack Adaptor    | FP2038   |
| Vinyl Tube Braided 1/4" (6mm) | AX5110   |

*Xtra* For more installation accessories take a look at our Aspen Xtra range

### HI-FLOW 1L & 2L OPTIONS

|            |          |
|------------|----------|
| Hi-flow 1L | FP2096/2 |
| Hi-flow 2L | FP2122/2 |

\* Other voltages available

### IN THE BOX

Hi-flow 1L or 2L pump • 2m Plug & play power cable • 2 StayClean tablets • Fixing kit • Install manual

Download manual at [aspenpumps.com](http://aspenpumps.com)

View install video at [aspenpumps.com](http://aspenpumps.com)



[aspenpumps.com](http://aspenpumps.com)

+44 (0)1323 848842

[sales@aspenpumps.com](mailto:sales@aspenpumps.com)

Making life easier for the installer